

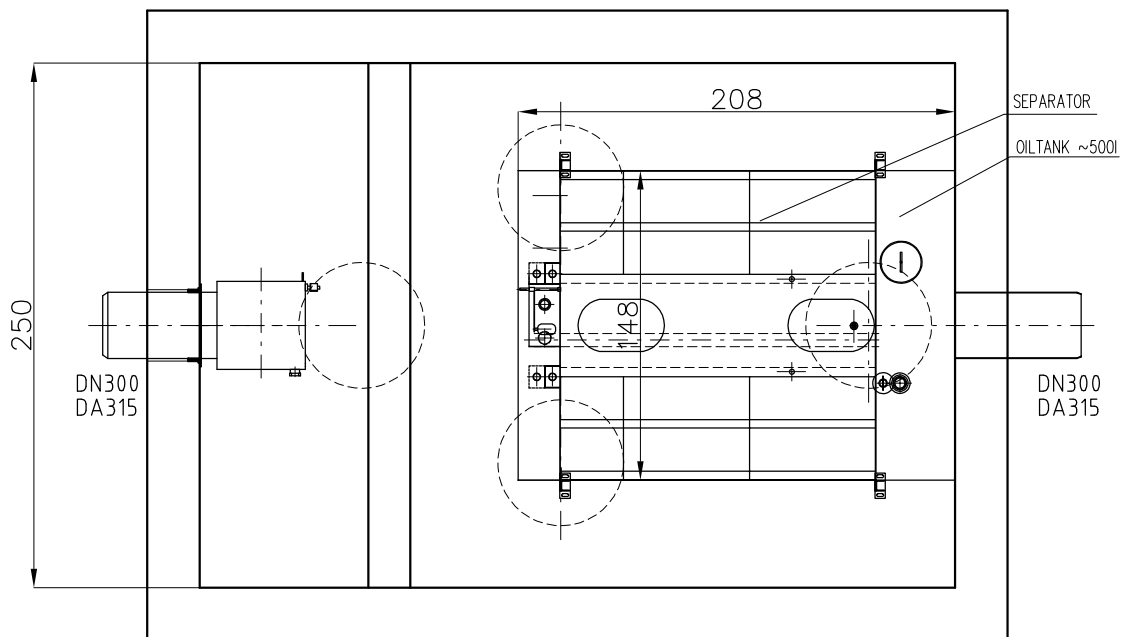

# High Performance Separator System H+ NS50

filter-less, stainless steel separator  
with integrated sludge trap  
with automatic oil skimming  
into the oil collection tank  
inflow closure

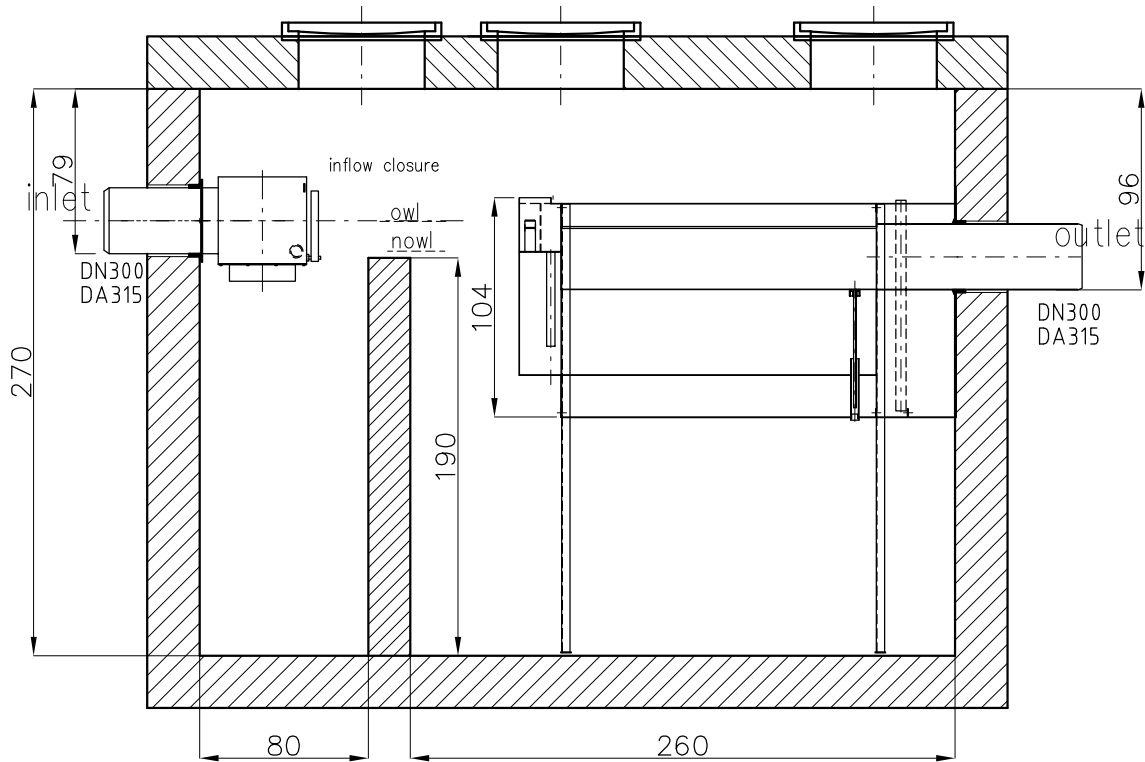

min. space requirements to basin for installation on inside!

Schwerstes Element:		FREIGABE: .....	DATUM:	PLANUNG/KONSTRUKTION:	 <b>Abwassertechnologie GmbH</b> <a href="http://www.inowa.at">www.inowa.at</a> A: Tel.: +43/7243/51414 A: Fax: +43/7243/5141415
Gesamtgewicht:			Unterschrift	25.2.2021	
-----	bauseits	Datum	MASS:	PROJEKT:	
			ZEICHNUNGNAME:		
			H+ NS50		
			ABWASSERPROJEKT		
			ZEICHNUNGSVERWALTER:		
			GEPLOTTET AM:		

techn. Änderungen vorbehalten!